

Business Storage and Logistics Solution



Shelving & Racking Systems

Warehouse full of Business ; Storage and Logistics Solution

Contents

	Page	Shelving System	Page
	Profile of Company 03		Longspan Rack 09
	Profile of Products 04		Medium Rack 09
Shelving System		Racking System	
	Wall Shelf 05		Selective Rack 10
	Mobile Cabinet 05		Drive-in Rack 11
	Minimart Shelf 06		Cantilever Rack 12
	Supermart Shelf 06		Special Rack 12
	Hypermart Shelf 07		Mezzanine Floor & Rack 14
	Integrated Shelf/Rack 07		Bravo Group of Companies 15
	Micro Shelf 08		Bravo Reference List 16
	Multi-Tiers Shelf 08		

HEAD OFFICE : 947/31 Bangnacomplex Building, (Todsapolland 4), Floor 7th, Bangna-Trad Road, Bangna, Bangkok 10260 Thailand.
Tel. 0-2398-8553 Fax: 0-2361-8518 <http://www.bravorack.com>

FACTORY : 30/10 Moo 3, Preecharach Road, Tumbol Ban Bueng, Aumphur Ban Bueng, Cholburi 20170 Thailand.



Profile of Company

MANUFACTURING FACILITIES

The factory occupies over 10,000 square meter of land area, of which 2 factories building covering over 3,000 square meter of production shops , office and finish product storage warehouse.

MAJOR PALNTS AND MACHINERY

Bravo production equipment comprise state of the art machinery with environmental awareness in concept, some of the major machines and plants are as follows :

- Numerical Controlled Upright Roll Forming Line For Large Profile
- Numerical Controlled Upright Roll Forming Line For Medium Profile
- Numerical Controlled Couple Beam Roll Forming Line
- Automatic Punching Line For Upright Profiles
- Automatic Punching Line For Gondola Post
- Cut-To-Length Line
- Hydraulic Press Brake 200Tons
- Mechanical Press Brake110Tons
- Mechanical Press75Tons
- Guillotine Shearing Machine
- Various Small Mechanical Presses 15 - 45 Tons
- Various Mig Welding Machines 215 - 350 Amps
- Array Of Spot Welding Machines 15 - 45 KVA
- Wire Straightening And Cut-To-Length Line 3.0 - 9.0 MM.
- Non-Polluted Bio-Degradable Spray Cleaning Surface Pre-Treatment Plant
- Continuous Electrostatic Epoxy Powder Paint Coating Line



MISSION :

WAREHOUSE FULL OF SOLUTIONS FOR BUSINESS DISPLAY AND STORAGE APPLICATIONS

ABOUT BRAVO INDUSTRY :

The establishment of Bravo Industry Co.,Ltd. Load by a group of Professionals from multi-disciplines of education and hand-on experience covering the whole spectrum of work functions to fulfill the needs to meet customer satisfactions both in the fields of business display as well as storage and warehouse logistic system.

Our Sales and Support Group comprises designers , engineers and support professions with over 15 years of hand-on experience in solving customers' problems ; Either in the design context for very large retailing stores with thousands of items to be displayed ; Or in solving and enhancing the problem of warehouse logistic flow. Our Manufacturing And Service Group comprises professionals with over 20 years of hand-on experience in steel fabrication , metal surface finishing and site supervision and installation in both domestic and oversea projects. Armed with modern manufacturing facilities and total individual professional experience of over 50 years in this industry ; Bravo Industry Co., Ltd. are fully confident in our best position to be partner in our customers' business success. Our mission : Warehouse Full Of Solutions For Business Display And Storage Applications.

Profiles of Products

Upright for Light Load - Medium Load

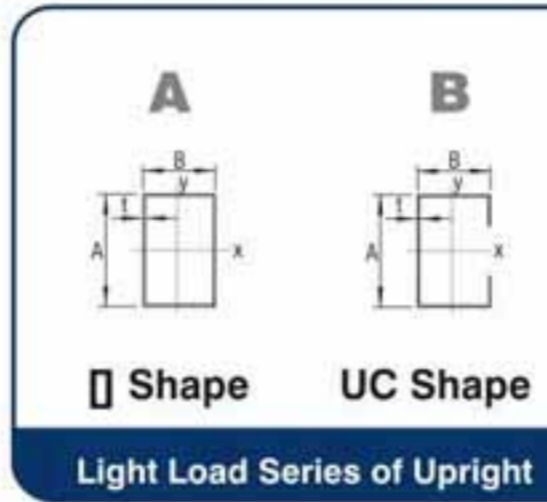
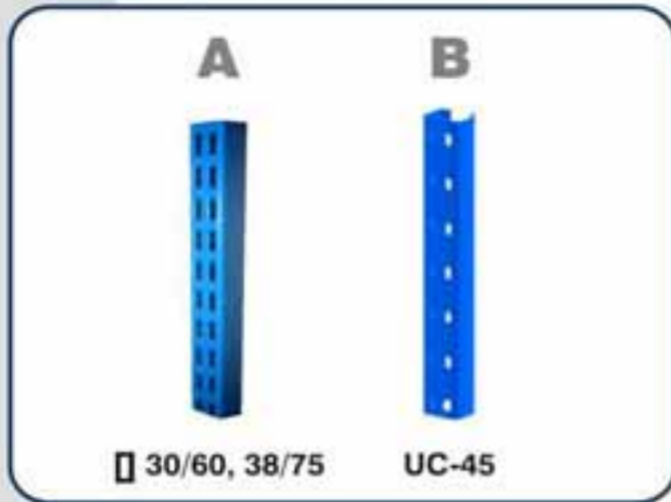

Series	Working of Beam
□ 30/60	Shelving System
□ 38/75	Hyper Shelving System
UC 45	Mini Longspan

Light Load Series of Upright

Upright for Standard/ Heavy/ Extra Heavy Load Selective Rack

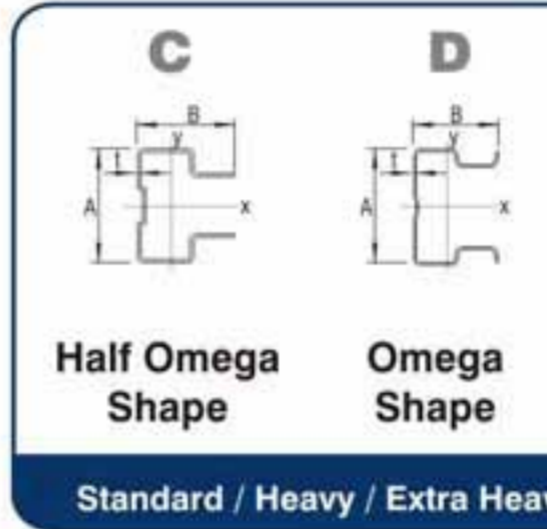
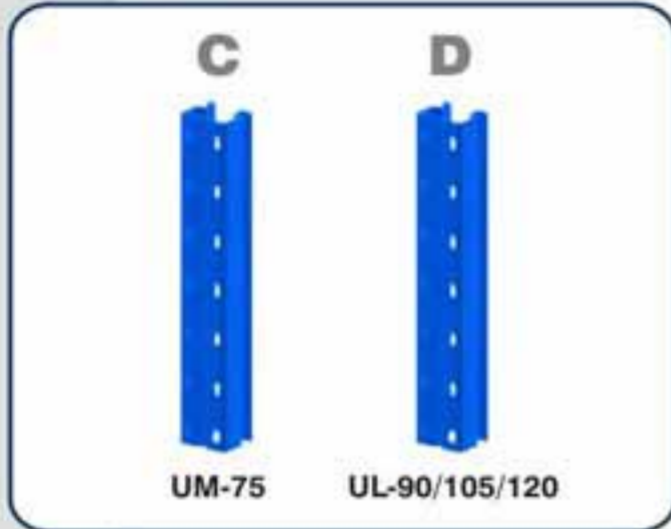

Series	Working of Beam
UM 75	Medium Racking System
UL 90	Standard Load Racking System
UL 105	Heavy Load Racking System
UL 120	Extra Heavy Load Racking System

Standard / Heavy / Extra Heavy Load Selective Rack Series of Upright

Beam for Light Load

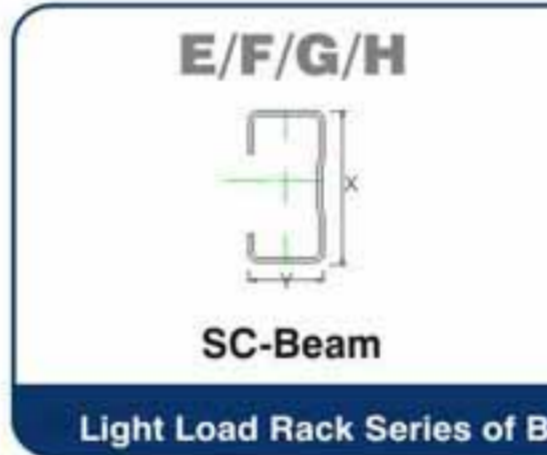
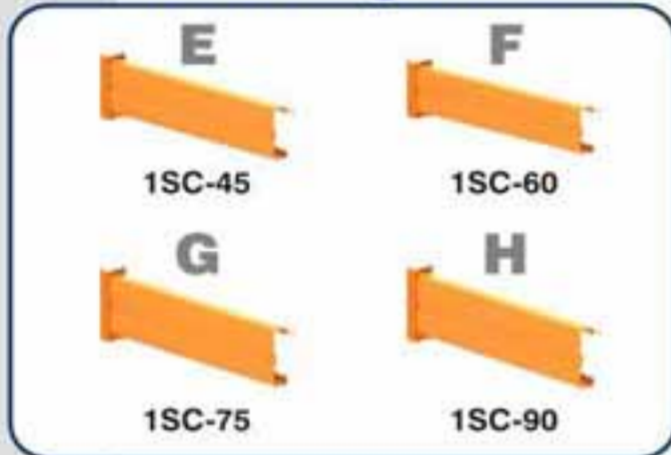

Series	Working of Beam
1SC 45	Light Load Beam
1SC 60	Light Load Beam
1SC 75	Light Load Beam
1SC 90	Light Load Beam

Light Load Rack Series of Beam

Beam for Standard Load

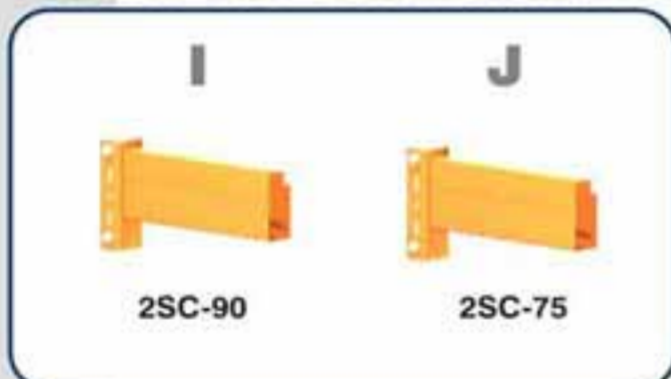

Series	Working of Beam
2SC 75	Step Load Beam
2SC 90	Step Load Beam

Step Load Rack Series of Beam

Beam for Heavy Duty Load

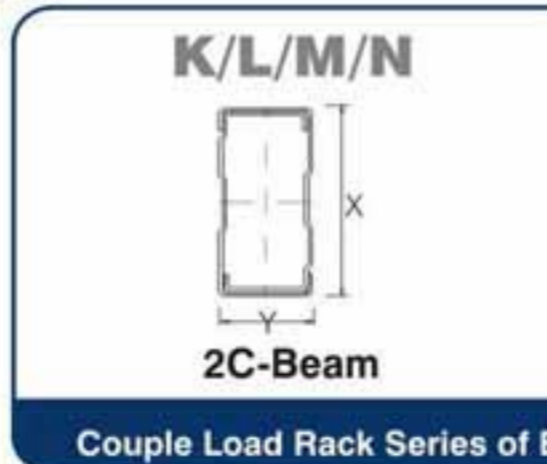
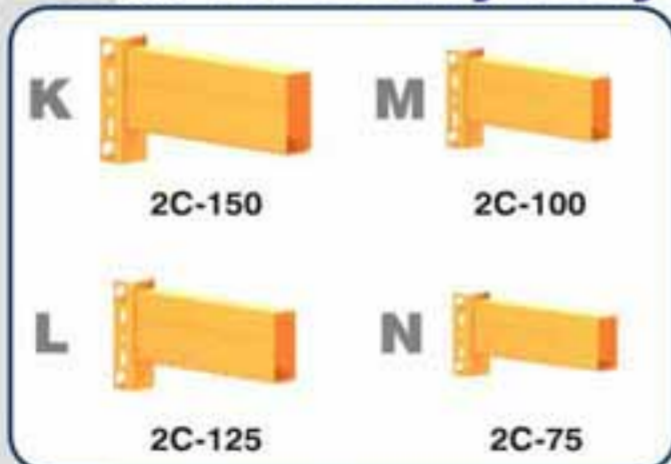

Series	Working of Beam
2C-150	Couple Load Beam
2C-125	Couple Load Beam
2C-100	Couple Load Beam
2C-75	Couple Load Beam

Couple Load Rack Series of Beam

Beam for Extra Heavy Duty Load

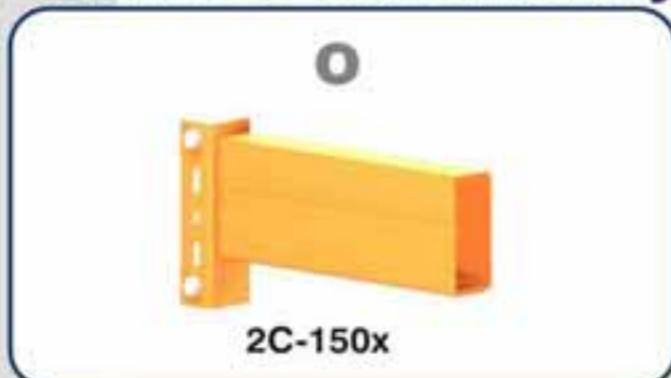

Series	Working of Beam
2C-150x	Heavy Couple Load Beam

Heavy Couple Load Rack Series of Beam

Wall-Mounted Shelving System

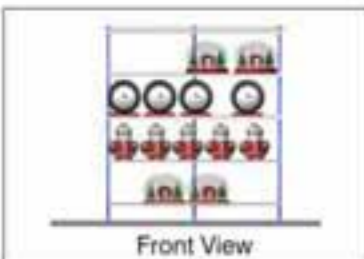
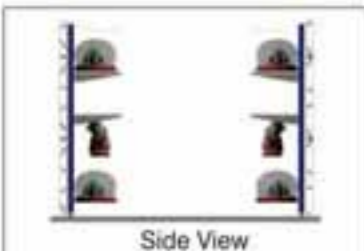

Wall-Mounted Shelving System

Wall - Mounted Shelving Designed to meet compact space utilization with adequate loading capacity for general use, up to 40 Kg. per level.

Suitable for both office and home application such as shelving for business files and other office equipment, garage storage shelving , kitchen shelving , etc.

Mobile Cabinet Shelving System

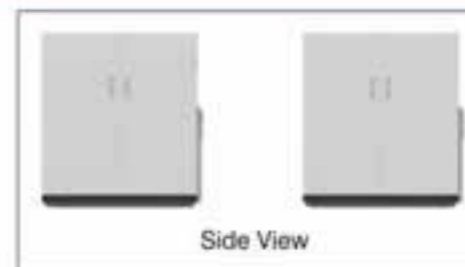

Mobile Cabinet Shelving System

Mobile Cabinet Shelving can be installed on carriages in tandem when close together forming a block. Resulting in very High Density Storage System for Document Files and Small Parts.

The system is totally modular and may be installed almost anywhere with ease. In case of unlevelled floor, the system can come with raised fault floor with its own floor leveling mechanism.

The system is available both with Mechanical Hand Wheel Drive Train and Manual Traction Handle.

Minimart Shelving System

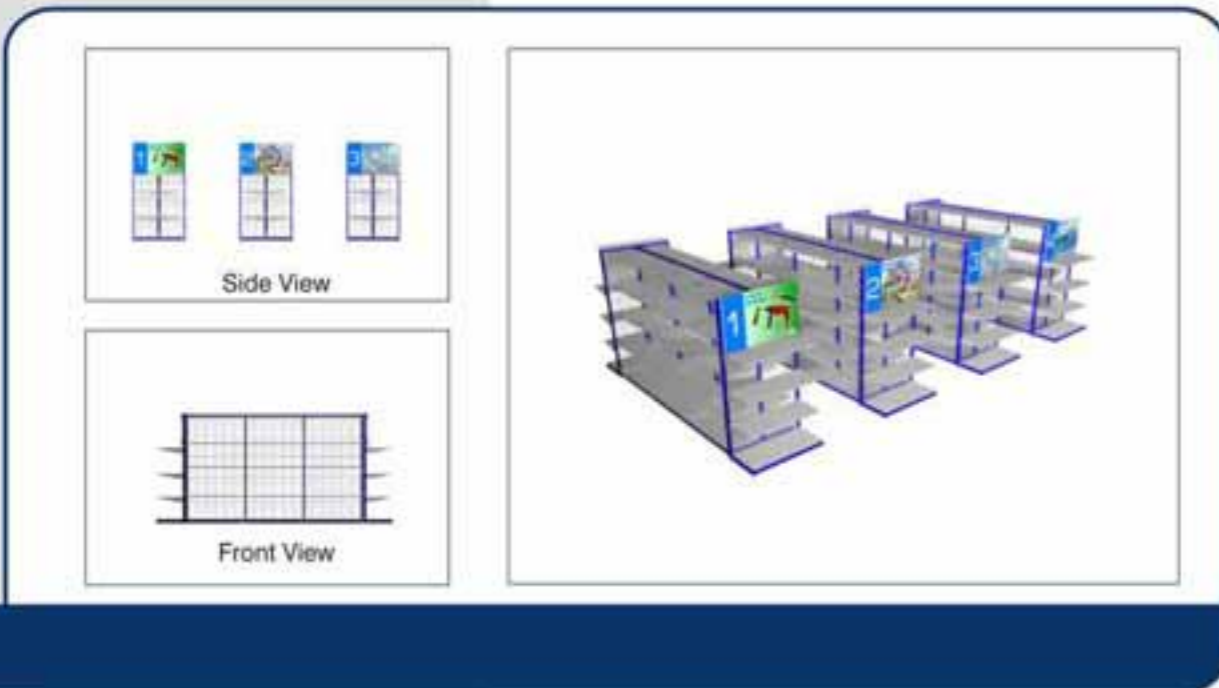

Supermart Shelving System



Minimart Shelving System

This light duty shelving system provides answer to most point-of-sale display function when load is not critical factor and low investment is desirable. Loading per level is designed at 40 Kg. and the shelving height can be up to 1.5 meter.



Hypermart Shelving System



Integrated Shelving System

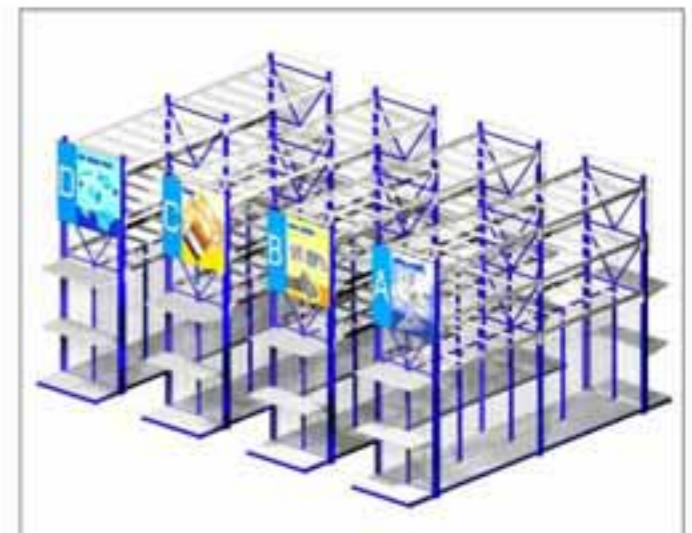
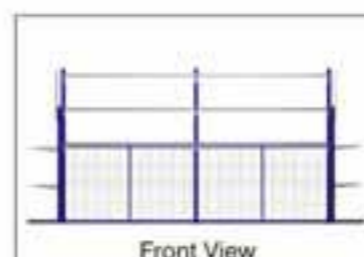
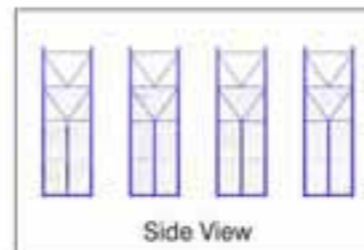
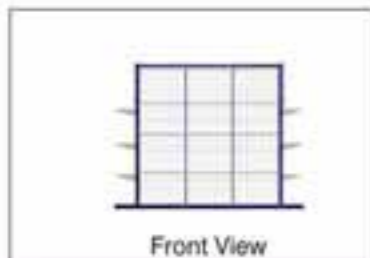

Hypermart Shelving System

This heavy duty shelving system is an answer to large retail store where heavy duty application is desirable, such as construction material and home builder store, large scale consumer product store. A great varieties of accessories for specialized displays is available. The loading per level is designed up to 120 Kg. per level and the upright for this series is general up to 2.4 meter high. Hi-Bay Hyper Mart Shelving system is also available with the storage height up to 4.0 meter.

Sanitary Ware Display



Swing Window Display



Door Lock Display



Integrated Rack/Shelving System

The integrated rack / shelving system is a multi-function equipment, merchandises can be displayed on the lower part, normally 2.0 - 2.2 meter from ground level, which allow the same function as general point-of-sale shelving system, the top part is used as storage facility for boxes, cartons or even the whole pallets. This combination eases replenishing operation as goods are stocked right at the same place as they are to be displayed, eliminating the need to built extra warehouse to stock merchandises. Bravo offer very extensive range of integrated rack/shelf system to suit any customer needs. System height varies from 2.40 meter up to 6.0 meter with standard depths of 1.0 meter and 1.20 meter.

Ceramic Tile Display



Mirror Display

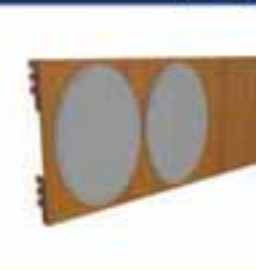

Swing Door Display



Micro Shelving System

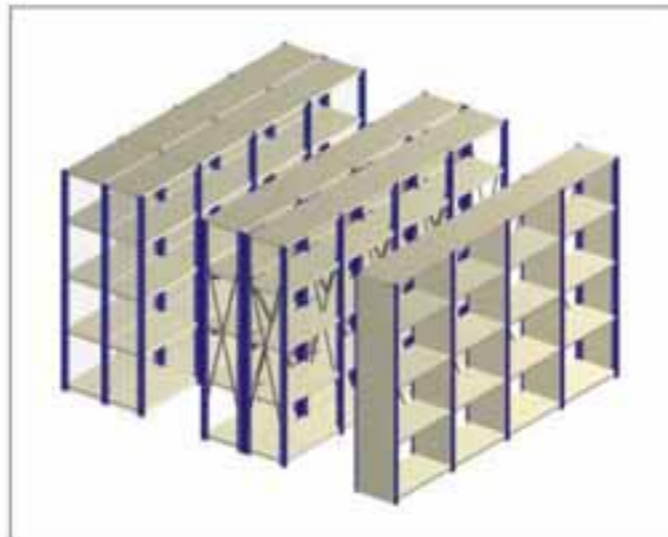
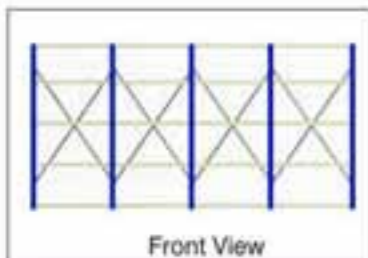
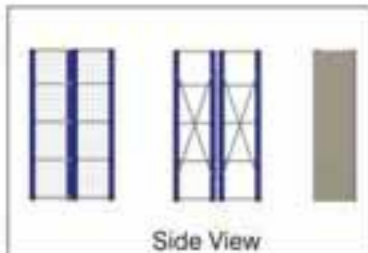

Micro Shelving System

Available in great many ranges and constructions. However, these will have the following basic components ;

Main part :

- : Post : steel post with profile of T-Section, or L-Section with prepunched slots along the post length.
- : Shelving : Per-fabricated steel shelf plate with or without stiffeners, Max load capacity 250 Kg. / level.
- : Back Stay : A pair of diagonal steel bars acts as anti side sway device..

Dimensions and Capacity of this micro shelf system :

- : Width : between 800 - 1200 mm.
 - : Depth : between 300 - 600 mm.
 - : Height : between 1500 - 3000 mm.
- Maximum storing weight 3000 Kg. / unit.

Multi-Tiers Shelving System

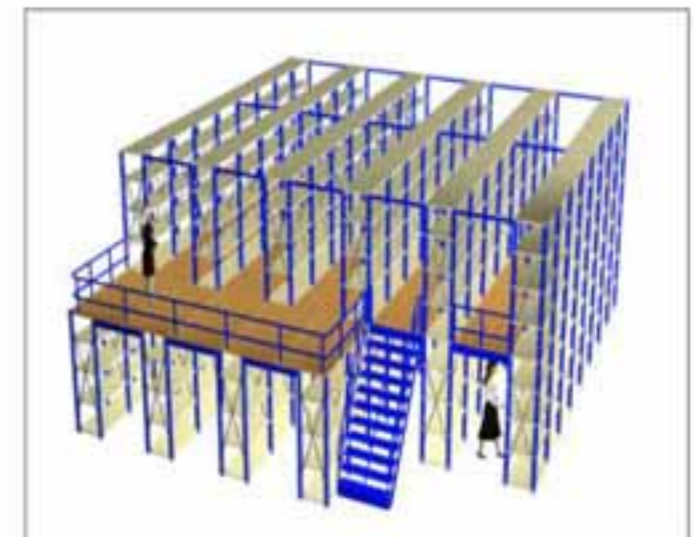
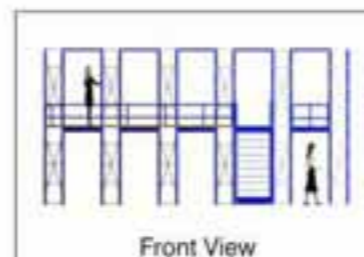
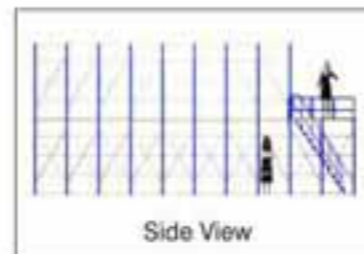

Multi-Tiers Shelving System

- Bay.** : A module between Uprights or Upright Frames.
- Run.** : A series of bays. connected lengthwise.
- Single Sided.** : Single depth of shelving, accessible from one side only.
- Double Entry.** : Single depth of shelving, accessible from both sides.
- Double Sided.** : Two runs built back to back not necessarily of the same depth.
- Levels.** : The number of storage levels in the height.
- Aisle.** : Space giving access to picking or loading faces.
- Gangway.** : Space for movement or transport but not giving direct access to picking or loading faces.

Longspan Racking System



Medium Racking System

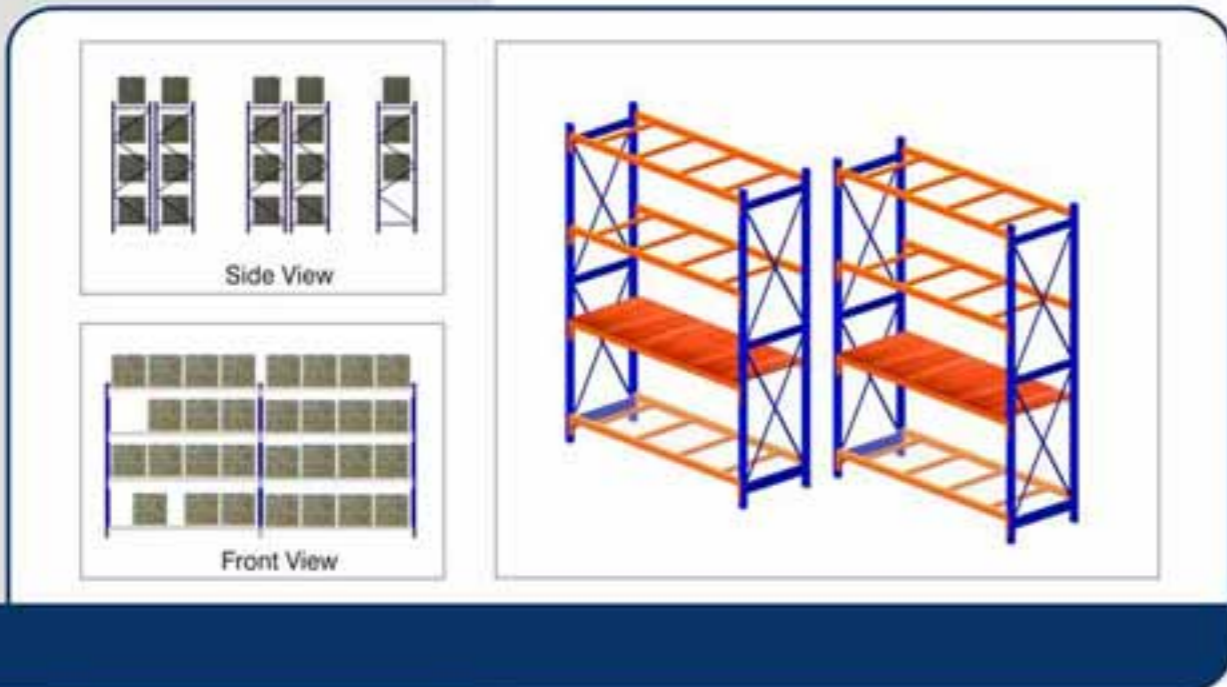

Longspan Racking System

The Series incorporate the structural upright frame of Load Capacity 4,500 Kg. Many Choices of LOAD BEAM ; Providing Load Capacity From 200 to 350 Kg. per Level. Multiple-Tiers Construction up to 2 Tiers Arrangement is also Possible.

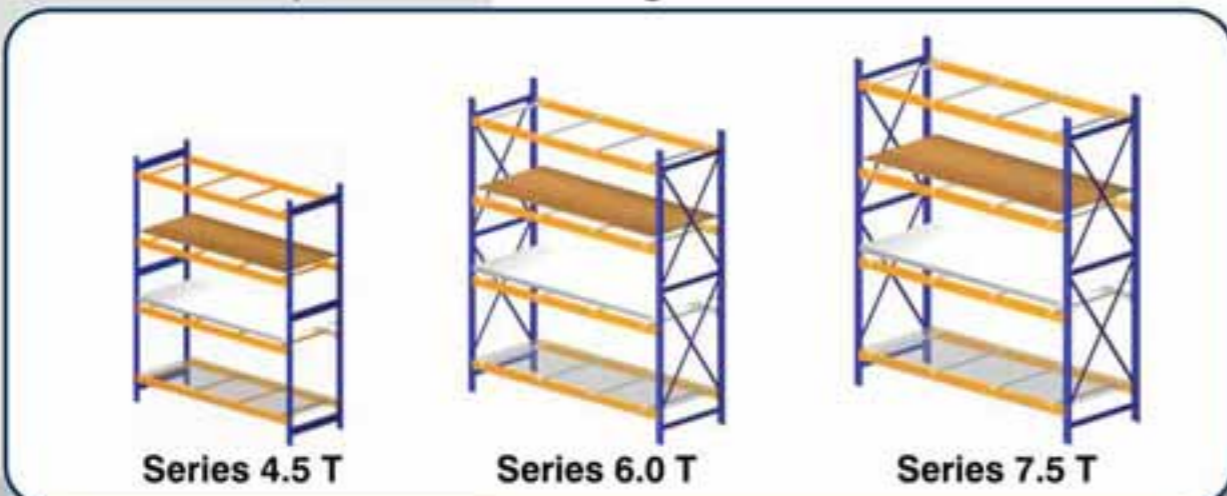

Medium Racking System

Medium Rack may be used for display and storage functions. When using within shop area the medium rack is used for paint and other heavy item such as water pump , electric motor etc. The standard module comprises a pair of upright frames with 4 load levels (8 load beams) and 5 cross beams for plywood decking. Steel decking is optional. The loading per level can be between 500 Kg. To 1,000 Kg. The standard module has the dimensions of 2.4 Meter (Width) x 0.8 Meter (Depth) x 2.4 Meter and 3.0 Meter (Height). Other sizes are also possible upon requested.

Selective Racking System

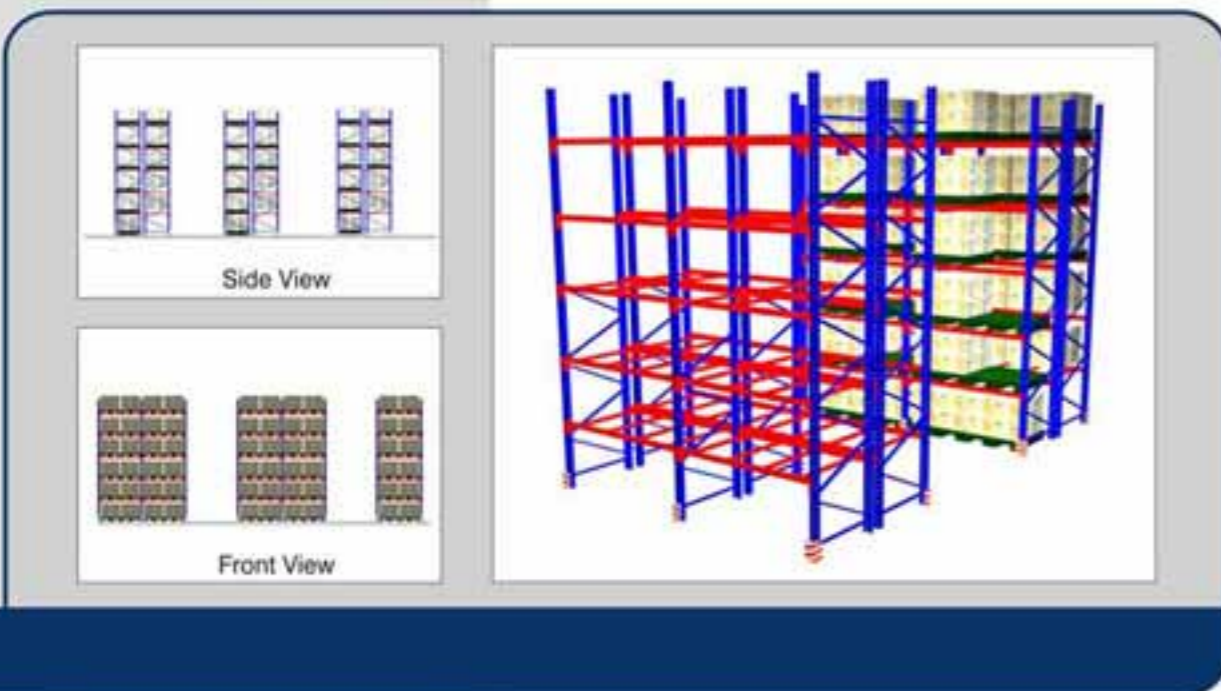

Parts of Selective Racking System

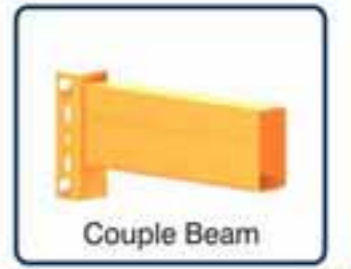
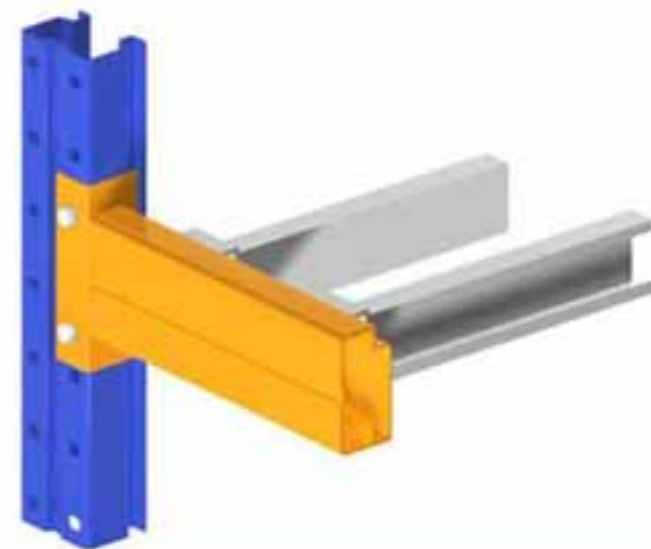

Type of Series

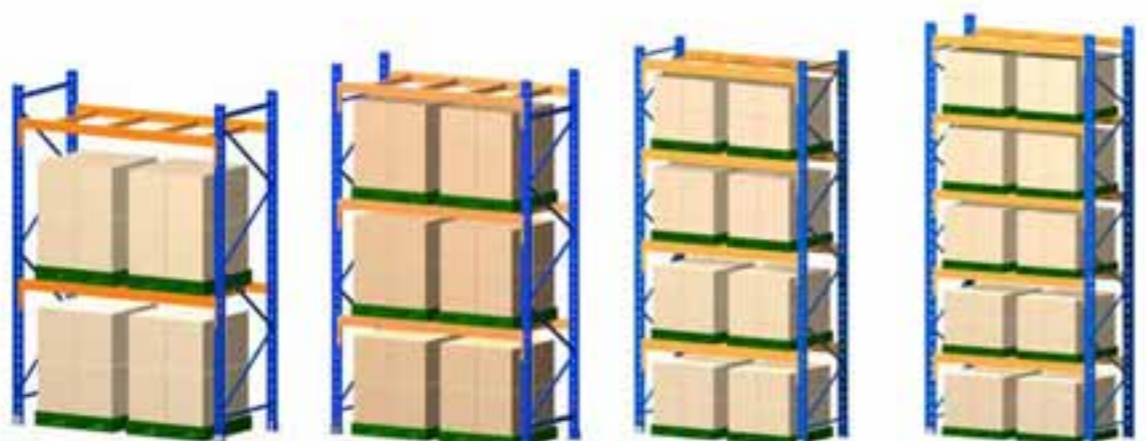

Series 7.5 T.

Series 9.5 T.

Series 11.5 T.

Series 12.5 T.

Selective Racking System

Basic prescription for most pallet storage problems. The selective rack is widely use as it is applicable to most storage requirements, access to every pallet stored is the key though space utilization may not be ideal.

Bravo solution to the wide usage range of selective rack is that of providing an extensive range of parts for selective rack , our standard upright frame starts from the height of 3.0 meter to 12.0 meter and covers the working compression load from 7.5 to 12.5 Tons per frame , higher loading is possible through special stiffener. A wide range of standard load beam is available from working load as low as 250 Kg. per level to as high as 5,000 Kg.

Drive in Racking System

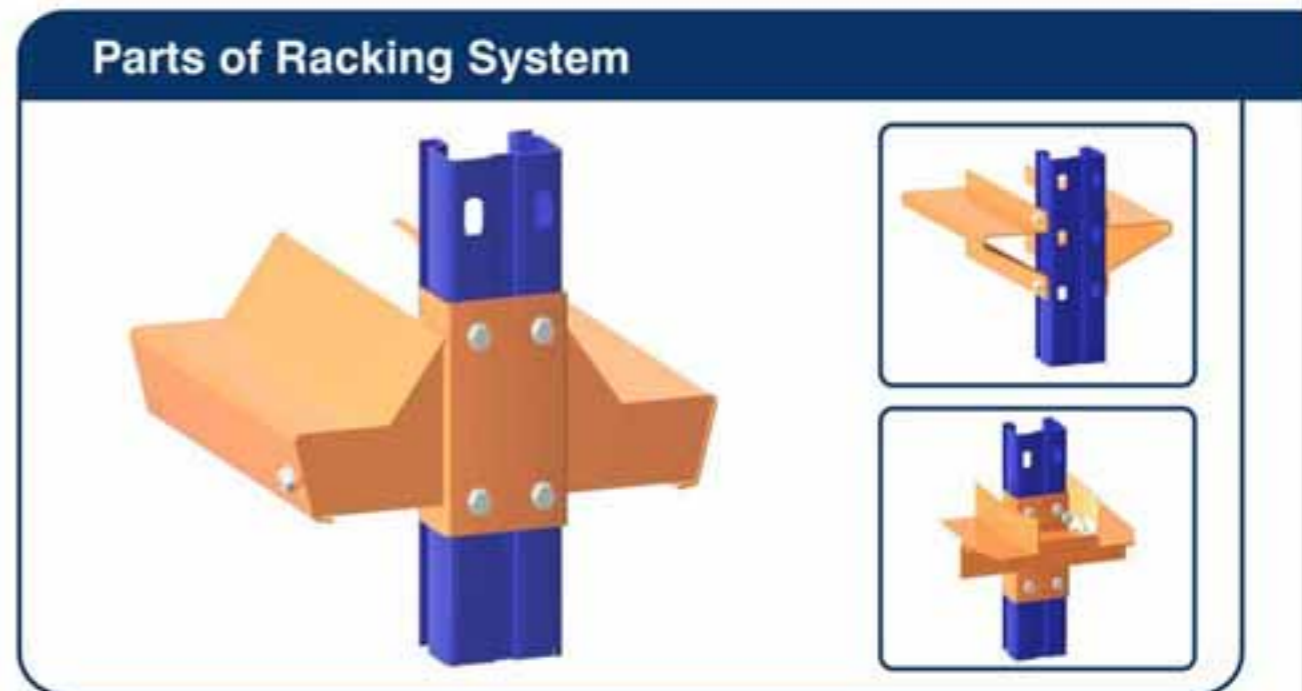

Drive in Racking System

The Drive-In Rack answers to high density storage requirement. A very good solution when space utilization is a critical factor, the weak point is that it is a First-In Last-Out system. This problem may be solved through lot control FIFO, or utilizing a Drive-Through system.

Bravo provides a wide range of Drive-In and Drive-Through Rack to meet all customer requirement concerning high density cubic storage. The upright frame can go up as high as 12.0 meter with 3, 4, 5 or 6 levels of pallet are possible. The upright frame loading starts from 2,500 Kg. Up to 5,500 Kg. per frame. Pallet rails of special design allow pallet load from 700 Kg. up to 2,000 Kg. Per pallet.

Cantilever Racking System

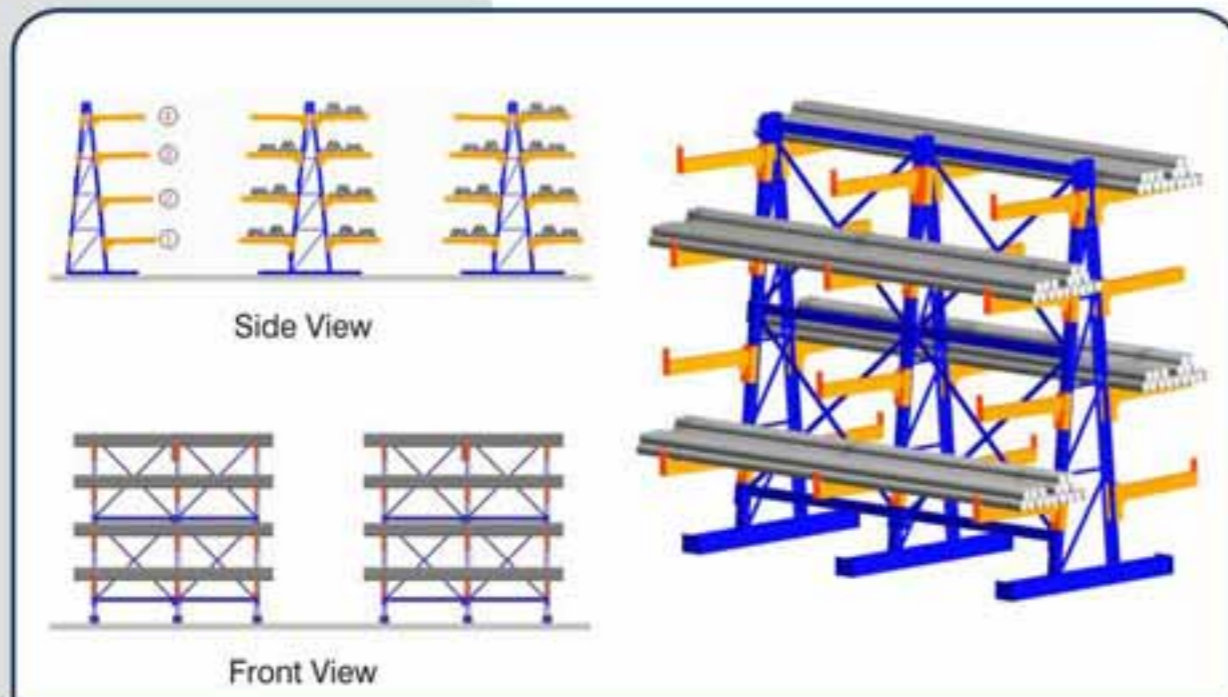

Cantilever Racking System

Long or irregular-length materials may be stored on this type of rack. Load bearing arms are cantilevered from vertical column, these arms may be adjusted along the vertical height to suit sizes of loads. The load may span the arms, steel or wooden desks can be fitted between the arms for storing materials which may not span a pair of arms, special profile desking is also possible for storing irregular shape and length such as roll of cloth, drum of wire, etc.

Special Racking System

Order Picking Racking System

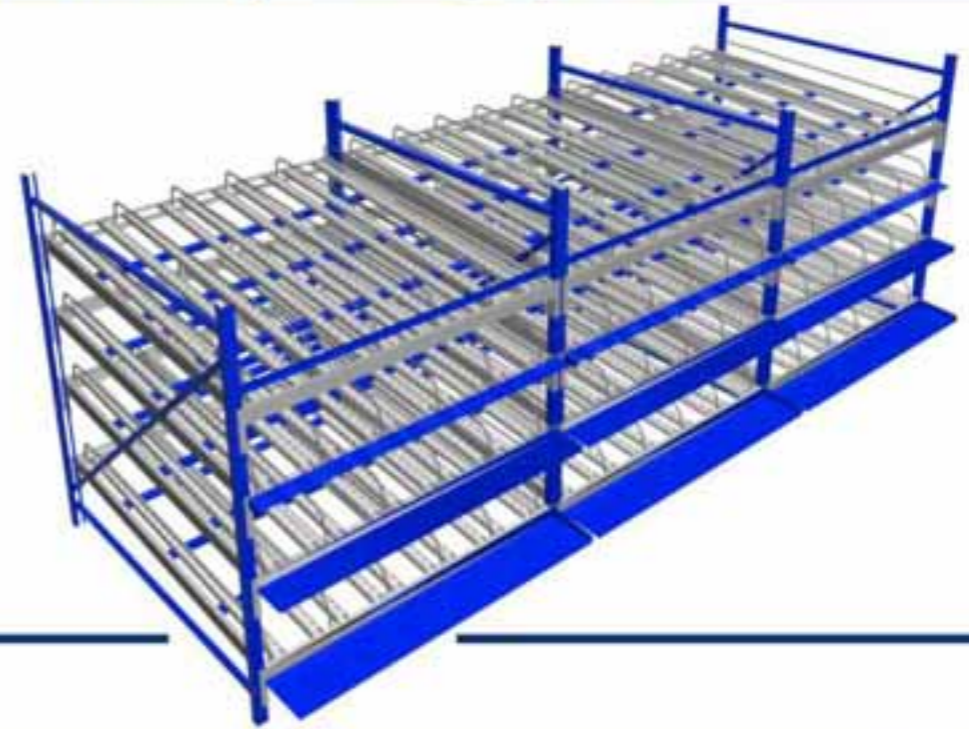

Slide Racking System

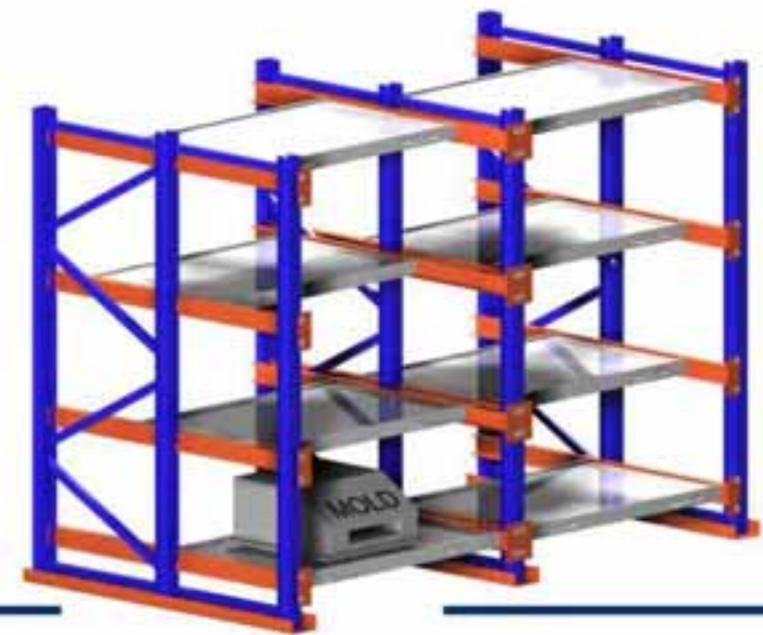

Push Back Racking System

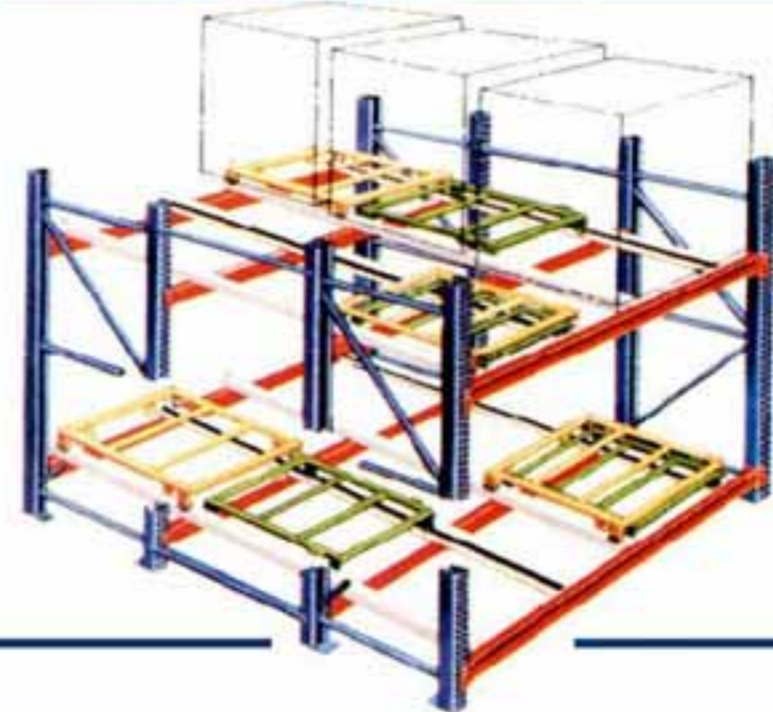

Flow and Roller Racking System



Mezzanine Racking System

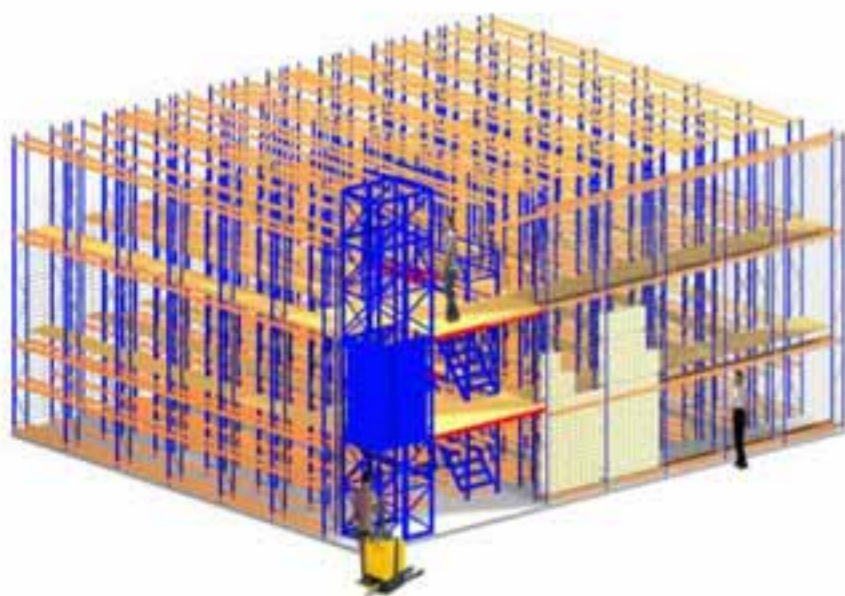

Mezzanine Racking System

The mezzanine rack is a fast and economic way to add extra space into the shell of an existing building.

Mezzanine floor provide easy way to separate storage zones into many used functions, such as separate storage and dispatch area, or fast moving and slow moving items, etc.

Bravo can design and custom made any load and dimensions requirement to our customer needs.

Rack Support Building System

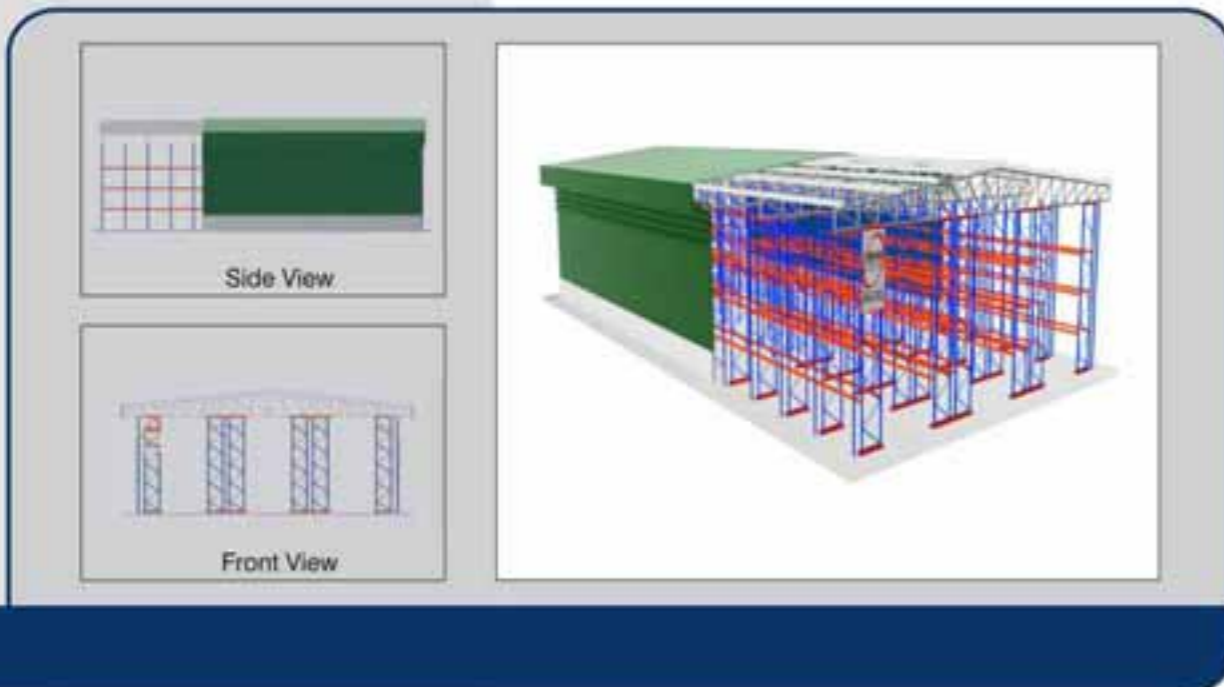

Rack Support Building System

When only pallet storage function is desirable, the rack support building is an economic and quick solution.

This is done by placing the roof structure upon the carefully designed rack upright, the metal sheet roofing and siding are the cladded on to the structure, constituted a storage building.

The installation is possible for either large or small storage facility.



Bravo Group of Companies

Bravo Industry Co.,Ltd.



Storage Racking System

เป็นชั้นวางสินค้า ที่ออกแบบให้เหมาะกับการนำไปจัดเก็บสินค้าที่มีน้ำหนักมาก และมีหลากหลาย แต่ละรายการมีปริมาณมากน้อยแตกต่างกัน สินค้าที่มีการเคลื่อนไหวเร็ว กลุ่มลูกค้าที่ใช้ เช่น ร้านขายวัสดุก่อสร้าง ศูนย์กระจายสินค้า คลังวัตถุดิบทั่วไป ที่ต้องการบริหารวัตถุดิบ ให้สอดคล้องกับการผลิต (just in time)

Mobile Cabinet Shelving System

ตู้เก็บเอกสารแบบเลื่อนได้ เป็นนวัตกรรมการออกแบบตู้เก็บเอกสารแบบทันสมัย เพื่อให้สนองต่อความต้องการของลูกค้าที่ใช้ตามแต่ละกลุ่มลูกค้า โดยคำนึงถึงการประหยัดพื้นที่ในสำนักงาน ตู้เก็บเอกสารแบบเลื่อนได้ จะมีความแตกต่างจากตู้เอกสารที่วางจำหน่ายในท้องตลาดทั่วไปอย่างสิ้นเชิง กลุ่มลูกค้าที่ใช้ เช่น กลุ่มสถาบันการเงิน โรงพยาบาล สำนักทะเบียนราษฎร์ ศาล ฯลฯ

Integrate Racking / Shelving System

ออกแบบเพื่อรองรับน้ำหนักได้มากกว่าชั้นซูเปอร์ทั่วไป พิเศษ มีชั้นจัดเก็บสต็อกอยู่ด้านบน เพื่อสะดวกในการเติมสินค้าในชั้นจำหน่าย เหมาะสำหรับ ร้านค้าทั่วไป ร้านจำหน่ายหนังสือ นิตยสาร ร้านส่งสมภัณฑ์ ร้านเครื่องเขียน ร้านขายยา ร้านอุปกรณ์ไฟฟ้า ร้านจำหน่ายฮาร์ดแวร์ และร้านวัสดุก่อสร้าง

Perfect Solution Asia Co.,Ltd.

บริการรับจ้างเหมาแรงงาน (Workforce Outsourcing)

Perfect Asia Solution ให้บริการรับจ้างเหมาแรงงาน ในทุกๆ ประเภทธุรกิจ ทุกตำแหน่งงานทั้งพนักงานทั่วไป และกลุ่มที่ใช้ทักษะ มีลูกค้าที่ให้ความไว้วางใจกว่า 50 บริษัท และมีพนักงานมากกว่า 2,000 คน พร้อมให้บริการ



Bravo & Supply Co.,Ltd.

บริการรักษาความปลอดภัย (Security Guard Service)

Bravo & Supply มีบริการรักษาความปลอดภัย เพื่อให้บริการกับโรงงานอุตสาหกรรม ห้างร้าน บริษัท ฯ หน่วยงานภาครัฐ เอกชน ทั่วไป

ความแตกต่างของการบริการ ความมุ่งมั่นในการดูแลรักษา ความปลอดภัยของทรัพย์สิน

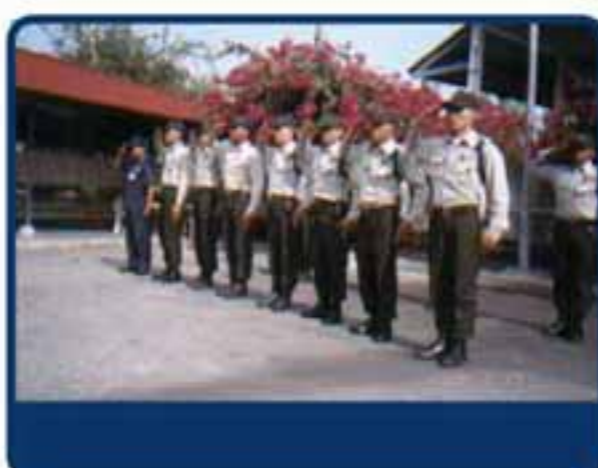

Tel: 0-2398-8553

Fax: 0-2361-8518

Bravo Reference List

Shelving System

Racking System

